



PEUGEOT

SON

CHOISIR L'EXPERIENCE, LA
TECHNOLOGIE... ET LE PLAISIR.
CHOISIR PEUGEOT

TOUTE PEUGEOT NAÎT D'UNE SECRÈTE ALCHIMIE OÙ ENTRENT LES ACQUIS D'UN SAVOIR-FAIRE ÉPROUVÉ ET LES RESSOURCES DE LA RECHERCHE TECHNOLOGIQUE. FIABILITÉ, ÉLÉGANCE, CONFORT, PERFORMANCES EN TOUS DOMAINES... CHAQUE PEUGEOT REPRODUIT LES QUALITÉS DE LA MARQUE - DONT LA 905 CONSTITUE LE PLUS RÉCENT FLEURON... VOILA POURQUOI, DANS LE MONDE ENTIER, DES MILLIONS D'UTILISATEURS SE FÉLICITENT JOUR APRÈS JOUR D'AVOIR CHOISI PEUGEOT.

CHOOSE EXPERIENCE, TECH-
NOLOGY... AND PLEASURE.
CHOOSE PEUGEOT

EVERY PEUGEOT IS BORN OF A SECRET ALCHEMY WHICH COMPRISES ACQUIRED AND WELL-PROVEN KNOW-HOW AND THE RESOURCES OF TECHNOLOGICAL RESEARCH. RELIABILITY, ELEGANCE, COMFORT, PERFORMANCES IN ALL AREAS... EACH PEUGEOT REPRODUCES THE QUALITIES OF THE MAKE - THE 905 BEING THE MOST RECENT FEATHER IN THEIR CAP... THIS IS WHY, THROUGHOUT THE WHOLE WORLD, MILLIONS OF USERS CONGRATULATE THEMSELVES DAY AFTER DAY ON HAVING CHOSEN PEUGEOT.

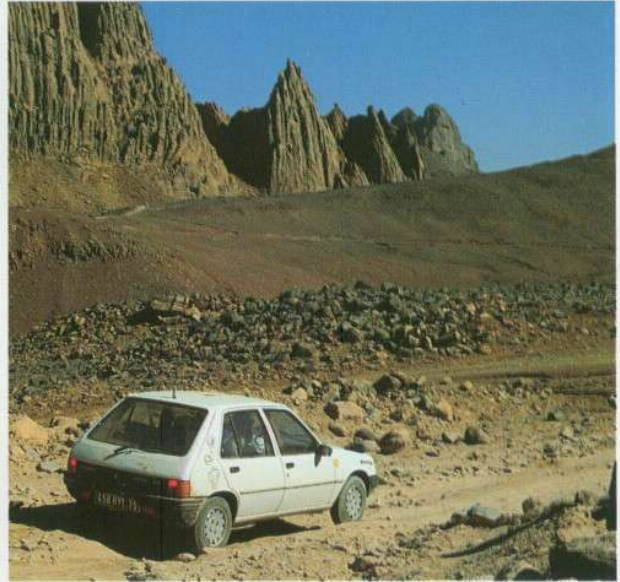
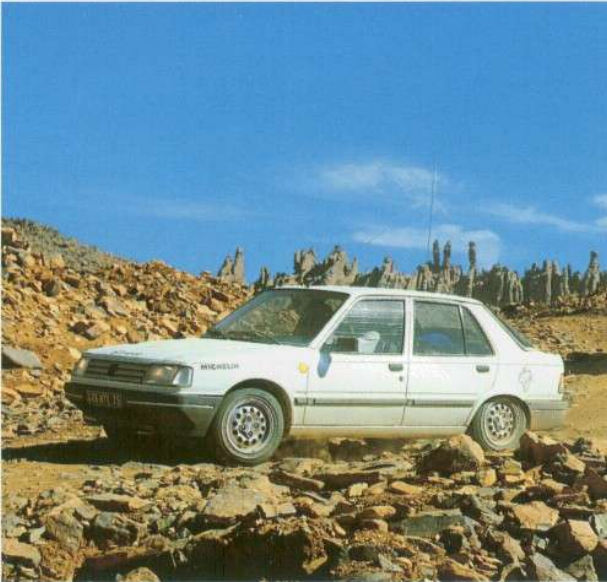







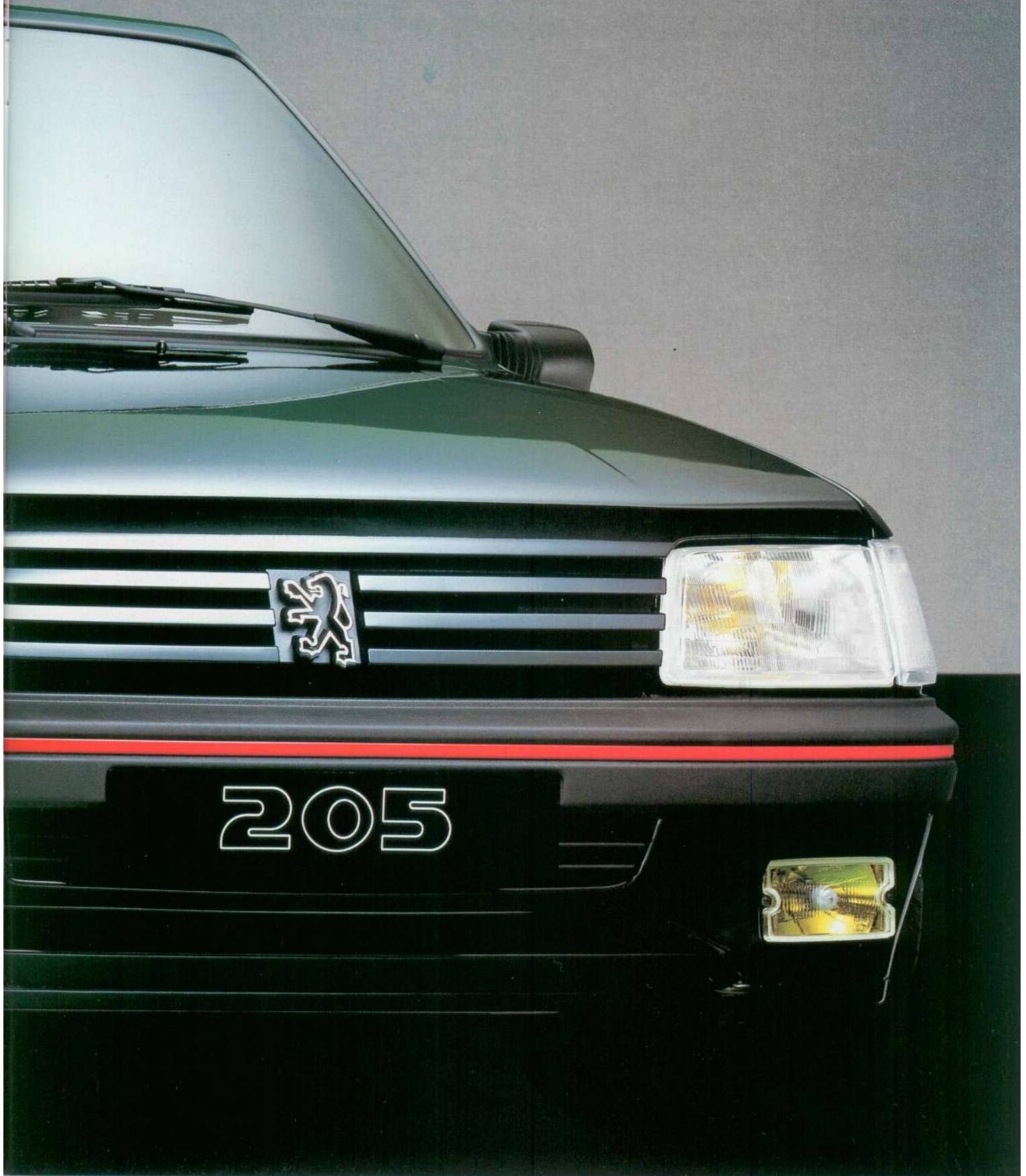







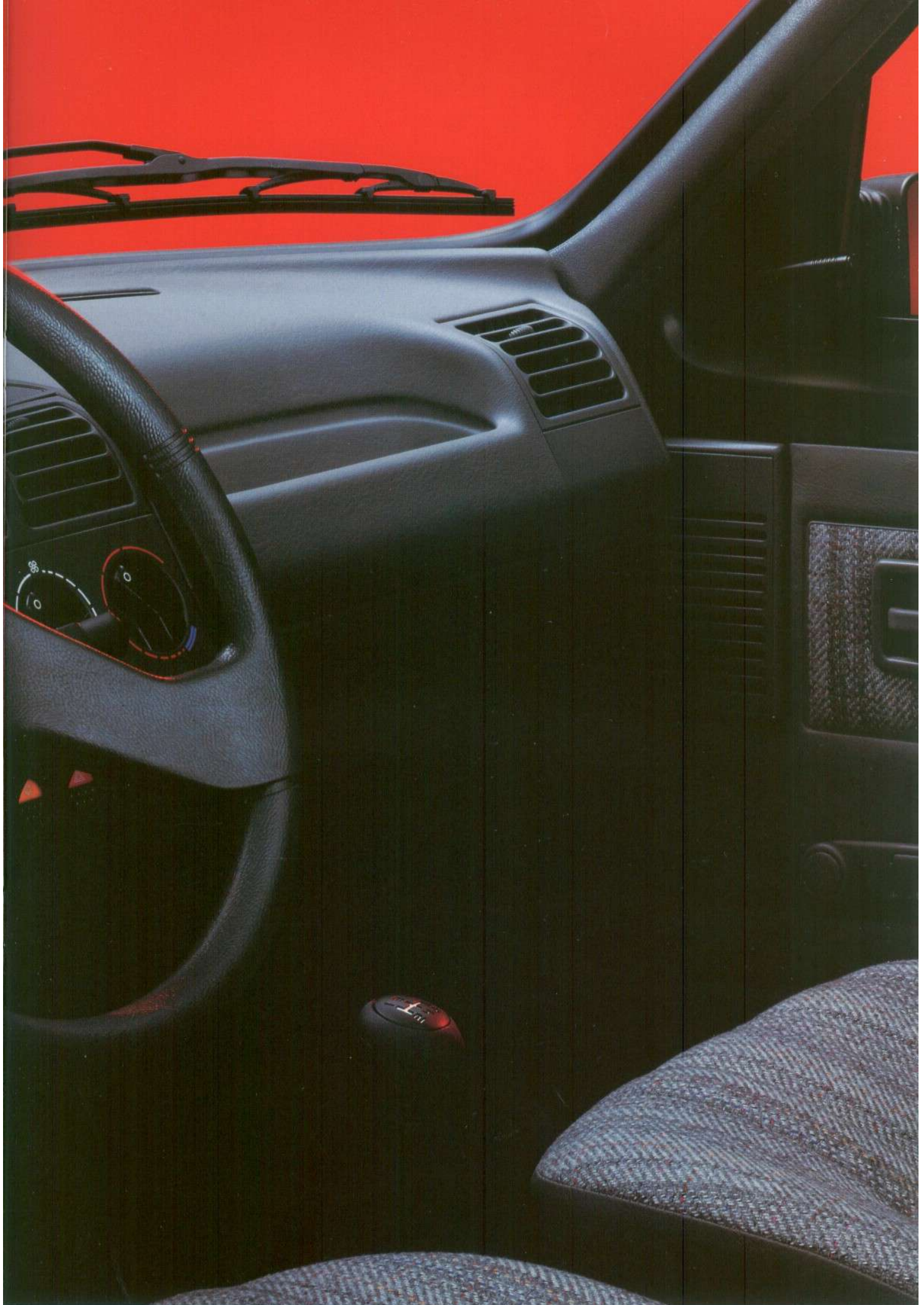





205 JUNIOR

205 JUNIOR



MOTEUR : ESSENCE 1 124 CM³

LA 205 JUNIOR COLLECTIONNE LES ADMIRATEURS... ET LEUR EN FAIT VOIR DE TOUTES LES COULEURS QUI COURENT EN FIN LISERÉ SUR SA CARROSSERIE ET SOULIGNENT SA LIGNE NERVEUSE ET ÉLÉGANTE. SI LE TISSU "JEAN", QUI RECOUVRE SES SIÈGES, PROUVE SA DÉCONTRACTION, ELLE N'EN A PAS MOINS LE SENS DU CONFORT : APPUIS-TÊTE, MOQUETTE BOUCLÉE, PRÉ-ÉQUIPEMENT RADIO, MIROIR DE COURTOISIE... NATURELLEMENT VIVE GRÂCE À SON MOTEUR ESSENCE 1 124 CM³ (55 CH DIN). ELLE SAIT AUSSI SE MONTRER TRÈS SÉCURISANTE : À L'AVANT, SES FREINS SONT À DISQUE AVEC ÉTRIER FLOTTANT ET SON FREINAGE EST ASSISTÉ PAR SERVO À DÉPRESSION.

ENGINE: PETROL 1.124 CC

THE 205 JUNIOR COLLECTS ADMIRERS... AND SHOWS THEM MORE COLORS. RUNNING AS A FINE BORDER ON ITS BODYWORK AND STRESSING ITS VIGOROUS AND ELEGANT LINE. IF THE "JEANS" FABRIC ON ITS SEATS PROVES ITS RELAXATION, IT NONETHELESS HAS A SENSE OF COMFORT: HEADREST, BOUCLÉ CARPETING, RADIO PRE-EQUIPMENT, COURTESY MIRROR... NATURALLY LIVELY THROUGH ITS 1.124 CC (55 HP DIN), PETROL ENGINE, IT HAS ALSO PROVEN ITSELF VERY SAFE: IN THE FRONT IT HAS DISK BRAKES WITH FLOATING CALIPER AND THE BRAKING IS POWERED BY VACUUM SERVO.

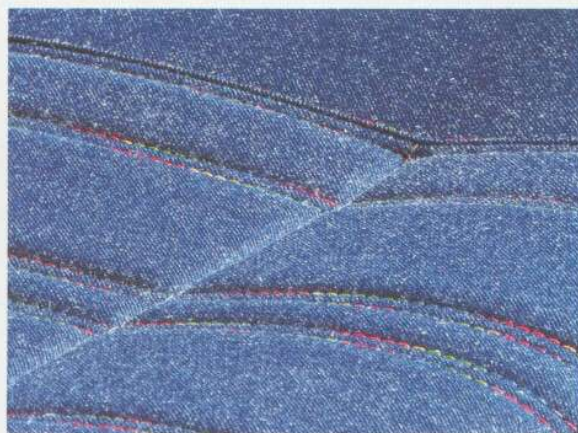

205 XL/GL/GLD

205 XL/GL/GLD



MOTEURS : ESSENCE 1 124 CM³
DIESEL 1 769 CM³

EN TROIS PORTES (205 XL) OU EN CINQ PORTES, VERSION ESSENCE (GL) OU DIESEL (GLD), CES 205 ONT EN COMMUN UN ÉQUIPEMENT DE TRÈS BON NIVEAU. LEURS SIÈGES, MUNIS D'APPUIS-TÊTE ET LEUR BANQUETTE ARRIÈRE RABATTABLE SONT REVÊTUS DE DRAP TRÈS ÉLÉGANT. ET LE BIEN-ÊTRE QU'ELLES PROCURENT EST RÉVÉLÉ PAR DE MULTIPLES DÉTAILS : ACCOUDOIRS DE PORTES À L'AVANT ET À L'ARRIÈRE (GL, GLD), RÉTROVISEUR INTÉRIEUR JOUR/NUIT, ALLUME-CIGARES, DÉGIVRAGE/DÉSEMBUAGE DE LUNETTE ARRIÈRE, MONTRE À QUARTZ, VIDE-POCHES... RÉSOLUMENT ÉCONOMES, LEURS MOTEURS - DIESEL OU ESSENCE À VOTRE CHOIX - SONT AUSSI ENDURANTS ET ÉTONNAMMENT PERFORMANTS...

ENGINES: PETROL 1.124 CC
DIESEL 1.769 CC

IN THE THREE-DOOR (205 XL) OR FIVE-DOOR, PETROL (GL) OR DIESEL (GLD) VERSIONS, THESE 205S HAVE IN COMMON A VERY GOOD LEVEL OF EQUIPMENT. THEIR SEATS WITH HEADRESTS AND THEIR FOLD-DOWN REAR BENCH SEAT ARE CLAD WITH VERY ELEGANT MATERIAL. AND THE WELL-BEING THEY PROCURE IS INDICATED BY NUMEROUS DETAILS: DOOR ARMRESTS IN THE FRONT AND REAR (GL, GLD), INTERIOR DAY/NIGHT DRIVING MIRROR, CIGAR LIGHTER, DEFROSTING/DEMISTING OF THE REAR WINDOW, QUARTZ CRYSTAL CLOCK, GLOVE COMPARTMENT... THEIR ENGINES - DIESEL OR PETROL, AS YOU WISH, ARE RESOLUTELY ECONOMICAL AND ALSO ENDURING AND ASTONISHINGLY PERFORMING.

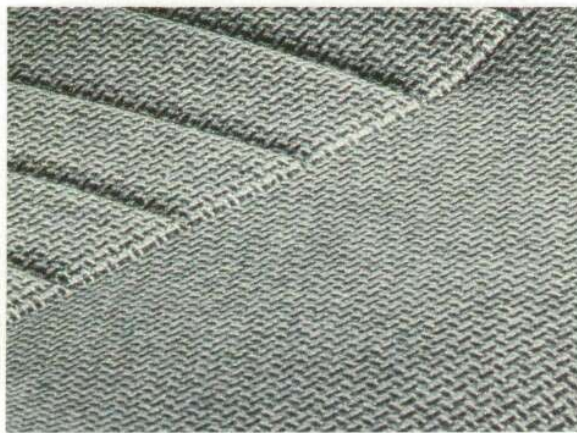

205 XR/GR/GRD

205 XR/GR/GRD



MOTEURS : ESSENCE 1 360 CM³
DIESEL 1 769 CM³

LES 205 XR - VERSION TROIS PORTES - GR ET GRD - VERSIONS CINQ PORTES - SONT DE VRAIES ÉLÉGANTES. UNE ÉLÉGANCE VISIBLE AU PREMIER COUP D'OEIL : BAGUETTES DE PROTECTION LATÉRALE, ENJOLIVEURS DE ROUES DE GRAND DIAMÈTRE, LAVE/ESSUIE-VITRE DE LUNETTE ARRIÈRE... À L'INTÉRIEUR, ELLES MULTIPLIENT LES PRÉVENANCES : DRAP COSSU SUR LES SIÈGES ET LA BANQUETTE RABATTABLE, BOÎTE À GANTS AVEC COUVERCLE, NOMBREUX VIDE-POCHES, MONTRE À QUARTZ... ENFIN, SUR TOUTES LES ROUTES, ELLES SAVENT S'IMPOSER PAR LEUR GRANDE VIVACITÉ - LE MOTEUR ESSENCE (XR ET GR) DÉVELOPPE 75 CH DIN, LE DIESEL DE LA GRD, 60 CH DIN - ET LEUR SOBRIÉTÉ EXTRÊME...

ENGINES: PETROL 1.360 CC
DIESEL 1.769 CC

THE 205 XR - THREE-DOOR VERSION - GR AND GRD - FIVE-DOOR VERSION - ARE TRULY ELEGANT. AN ELEGANCE VISIBLE AT FIRST GLANCE: PROTECTIVE BEADS ON THE SIDES, LARGE-DIAMETER WHEEL COVERS, WINDSHIELD WIPER/WASHER ON THE REAR WINDOW... INSIDE, THE EXTRAS ARE NUMEROUS: RICH FABRIC ON THE SEATS AND FOLD-DOWN BENCH SEAT, GLOVE COMPARTMENT WITH LID, NUMEROUS PARCEL TRAYS, QUARTZ CRYSTAL CLOCK... FINALLY ON ROADS, THEY IMPOSE THEMSELVES THROUGH THEIR VIVACITY - THE PETROL ENGINE (XR AND GR) DEVELOPS 75 HP DIN AND THE DIESEL ON THE GRD, 60 HP DIN - TOGETHER WITH EXTREME ECONOMY.



205 SR

205 SR



MOTEUR : ESSENCE 1 360 CM³
 LA 205 SR EST RAFFINÉE. POUR SES SIÈGES, SES PANNEAUX DE PORTE ET SA BANQUETTE ARRIÈRE, ELLE A CHOISI LE PLUS LUXUEUX DES VELOURS. COURTOISE, ELLE OFFRE BOÎTE À GANTS ÉCLAIRÉE, MONTRE DIGITALE, ÉCLAIRAGE DU TABLEAU DE BORD RÉGLABLE PAR RHÉOSTAT ET MILLE ET UNE AUTRES ATTENTIONS : LÈVE-VITRES ÉLECTRIQUES AVANT, VERROUILLAGE CENTRALISÉ DES PORTES ET DU HAYON, RÉTROVISEURS RÉGLABLES DE L'INTÉRIEUR... ELLE MANIFESTE, DE PLUS, UN SENS PRATIQUE TRÈS POUSSÉ : SA BANQUETTE ARRIÈRE RABATTABLE PAR MOITIÉ EN TÉMOIGNE. ET COMME SON MOTEUR DE 75 CH DIN EST UN MODÈLE DE SOUPLESSE, DE PERFORMANCES ET DE SOBRIÉTÉ, IL DEVIENT BIEN DIFFICILE DE NE PAS SUCCOMBER À SON ACTIVE SÉDUCTION...

ENGINE: PETROL 1.360 CC
 THE 205 SR IS RAFFINED. FOR ITS SEATS, DOOR PANELS AND REAR BENCH SEAT IT HAS ADOPTED THE MOST LUXURIOUS OF VELVET FABRICS. COURTEOUS AS IT IS, IT OFFERS AN ILLUMINATED GLOVE COMPARTMENT, A DIGITAL CLOCK ADJUSTABLE BY RHEOSTAT, LIGHTING ON THE DASHBOARD AND 1001 OTHER ATTENTIONS: ELECTRICAL WINDOW LIFTS IN THE FRONT, CENTRALIZED LOCKING OF THE DOOR AND TAILGATE, DRIVING MIRRORS ADJUSTABLE FROM THE INSIDE... MOREOVER, IT MANIFESTS A VERY ADVANCED PRACTICAL SENSE: ITS REAR BENCH SEAT FOLDED DOWN BY HALF IS EVIDENCE OF THIS. AND AS ITS 75 HP DIN ENGINE IS A MODEL OF FLEXIBILITY, PERFORMANCE AND ECONOMY, IT IS VERY DIFFICULT NOT TO SUCCUMB TO ITS ACTIVE SEDUCTION...



205 XS

205 XS



MOTEUR : ESSENCE 1 360 CM³
DU PUNCH, LA 205 XS EN A À REVENDRE. DE LA SPORTIVE ACCOMPLIE, ELLE EN A LA ROBE ET LES CAPACITÉS. SON MOTEUR 1 360 CM³ (85 CH DIN) NOURRI PAR CARBURATEUR DOUBLE CORPS, RESPIRE LA SANTÉ ET LUI OCTROIE DES PERFORMANCES DE TOUT PREMIER PLAN. A L'EXTÉRIEUR, ELLE IMPRESSIONNE. ÉQUIPÉE DE PHARES LONGUE-PORTÉE INTÉGRÉS À LA JUPE AVANT, ORNÉE D'UNE BAGUETTE DE PROTECTION LATÉRALE SOULIGNÉE D'UN FILET...ELLE A BEAUCOUP D'ALLURE. UNE ALLURE QUI NE SE DÉMENT PAS À L'INTÉRIEUR : TOUS LES INGRÉDIENTS DE LA CONDUITE SPORTIVE Y FIGURENT, TELS LES SIÈGES AVANT TYPE BAQUET ET LE TABLEAU DE BORD ULTRA-COMPLET...

ENGINE: PETROL 1.360 CC
THE 205 XS HAS SUFFICIENT PUNCH TO SPARE. IT HAS THE DRESSING AND CAPABILITIES OF AN ACCOMPLISHED SPORTS CAR. ITS 1.360 CC (85 HP DIN) ENGINE FED BY TWO-BARREL CARBURETOR, RADIATES HEALTH AND OFFERS IT FIRST CLASS PERFORMANCES. ON THE OUTSIDE IT IS IMPRESSIVE: EQUIPPED WITH LONG-RANGE HEADLIGHTS INTEGRATED INTO THE FRONT SKIRT, DECORATED WITH A PROTECTIVE BEAD ON THE SIDE OUTLINED WITH A STRIPE... IT HAS A FINE APPEARANCE, AN APPEARANCE WHICH IS NOT CONTRADICTED INSIDE: ALL THE INGREDIENTS OF SPORTING DRIVING ARE THERE, SUCH AS BUCKET TYPE FRONT SEATS AND THE ULTRA-COMplete DASHBOARD...



205 GTI 1,6/1,9

205 GTI 1,6/1,9



MOTEURS : ESSENCE 1 580 CM³/1 905 CM³
ASSOCIER LE LUXE À LA SPORTIVITÉ, OFFRIR LE PLUS HAUT NIVEAU DE PERFORMANCES ET DE SÉCURITÉ, TELLE EST LA VOCATION COMMUNE DES 205 GTI. LA DIFFÉRENCE ? LA 205 GTI 1,6 EST ANIMÉE PAR UN 1 580 CM³, 115 CH DIN, LA 205 GTI 1,9, PAR UN 1 905 CM³ QUI DÉVELOPPE 130 CH DIN. ET SI TOUTES DEUX OFFRENT UN FREINAGE ASSISTÉ ET DES FREINS À DISQUE VENTILÉ À L'AVANT, CEUX DE L'ARRIÈRE SONT ÉGALEMENT À DISQUE SUR LA 205 GTI 1,9. MAIS LES 205 GTI REPRÉSENTENT SURTOUT UN ÉTAT D'ESPRIT UNIQUE, QU'ATTESTENT UNE MULTITUDE DE DÉTAILS : LE VOLANT GAINÉ DE CUIR, QUI COMMANDE UNE DIRECTION PRÉCISE ET DIRECTE PAR EXEMPLE, OU ENCORE LES MAGNIFIQUES JANTES D'ALLIAGE LÉGER...

ENGINES: PETROL 1.580 CC/1.905 CC
ASSOCIATE LUXURY WITH SPORTIVENESS, OFFER THE HIGHEST LEVEL OF PERFORMANCE AND SAFETY, THIS IS THE JOINT VOCATION OF THE 205 GTI. WHAT IS THE DIFFERENCE? THE 205 GTI 1.6 IS DRIVEN BY A 1.580 CC, 115 HP DIN ENGINE AND THE 205 GTI 1,9 BY A 1.905 CC ENGINE DEVELOPING 130 HP DIN. AND ALTHOUGH BOTH OFFER POWERED BRAKING AND VENTILATED DISC BRAKES IN FRONT, THOSE AT THE BACK ARE ALSO DISC TYPE ON THE 205 GTI 1,9. BUT THE 205 GTIS ABOVE ALL CORRESPONDS TO A UNIQUE STATE OF MIND INDICATED BY NUMEROUS DETAILS: THE LEATHER-SHEATHED STEERING WHEEL, WHICH CONTROLS EXACT AND DIRECT STEERING, FOR EXAMPLE, OR AGAIN THE MAGNIFICENT LIGHT ALLOY WHEELS.



MOTORISATIONS : LE SOUCI DE L'EXCELLENCE...

LE SOUCI DE L'EXCELLENCE, QUI A PRÉSIDÉ À LA NAISSANCE DE CHAQUE 205 SE TRADUIT AUSSI PAR LE CHOIX DE MOTORISATIONS QUI FONT AUTORITÉ À LEUR NIVEAU DE PRESTATION. TOUTE 205 EST AINSI ÉQUIPÉE D'UN MOTEUR DE CONCEPTION TRÈS ACTUELLE - ARBRE À CAMES EN TÊTE ENTRAÎNÉ PAR COURROIE CRANTÉE - DONT LE REFROIDISSEMENT A ÉTÉ ADAPTÉ AUX CONDITIONS LES PLUS DIFFICILES, PERFORMANT, ENDURANT, SOUPLE ET FORT SOBRE...

THE ENGINES: THE CONCERN FOR EXCELLENCE...

THE CONCERN FOR EXCELLENCE WHICH HAS PREVAILED OVER THE BIRTH OF EACH 205 IS ALSO EXPRESSED BY THE CHOICE OF ENGINES WHICH ARE AN AUTHORITY AT THEIR LEVEL. EVERY 205 IS THUS EQUIPPED WITH AN ENGINE OF VERY MODERN DESIGN - OVERHEAD CAMSHAFT DRIVEN BY A NOTCHED BELT WHOSE COOLING IS ADAPTED TO THE MOST DIFFICULT CONDITIONS, HIGH PERFORMANCE, ENDURING, FLEXIBLE AND VERY ECONOMICAL.



COUPLE À BAS RÉGIME ET SOBRIÉTÉ POUR LES 205 JUNIOR, XL ET GL (1 124 CM³ DE 55 CH DIN - 40 kW CEE). UN BON SOUFFLE POUR LES 205 XR, GR ET SR (1 360 CM³, 75 CH DIN - 55 kW CEE).

BEAUCOUP D'ALLANT POUR LA 205 XS (1 360 CM³, 85 CH DIN - 61,5 kW CEE).

PUISSANCE ET BRIO EXCEPTIONNELS POUR LES 1 580 CM³ ET 1 905 CM³ (115 ET 130 CH DIN, 83 ET 93,5 kW CEE) DES 205 GTI.

STUPÉFIANT RAPPORT PERFORMANCES/CONSOMMATION POUR LES 205 GLD ET GRD À MOTEUR DIESEL (1 769 CM³) - 60 HP DIN - 43,5 kW CEE.

TORQUE AT LOW SPEED AND ECONOMY FOR THE 205 JUNIOR, XL AND GL (1 124 CC AND 55 BHP - 40 kW EEC). A GOOD PUNCH FOR THE 205 XR, GR AND SR (1 360 CC, 75 BHP - 55 kW EEC). A LOT OF GO IN THEM FOR THE 205 XS (1 360 CC, 85 BHP - 61.5 kW EEC). EXCEPTIONAL POWER AND SPIRIT FOR THE 1 580 CC AND 1 905 CC (115 AND 130 BHP, 83 AND 93.5 kW EEC) OF THE 205 GTI. ASTONISHING PERFORMANCE/ CONSUMPTION RATIO FOR THE DIESEL-ENGINEED 205 GLD AND GRD (1 769 CC) - 60 BHP - 43.5 kW EEC.

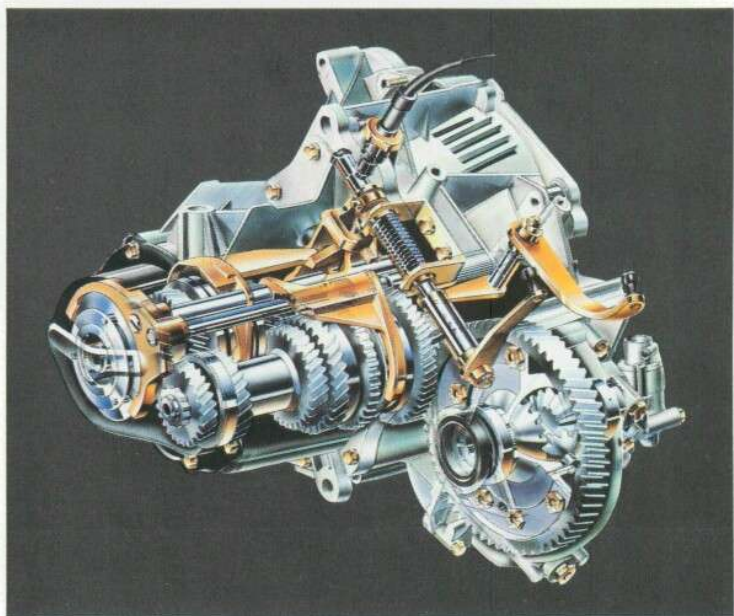
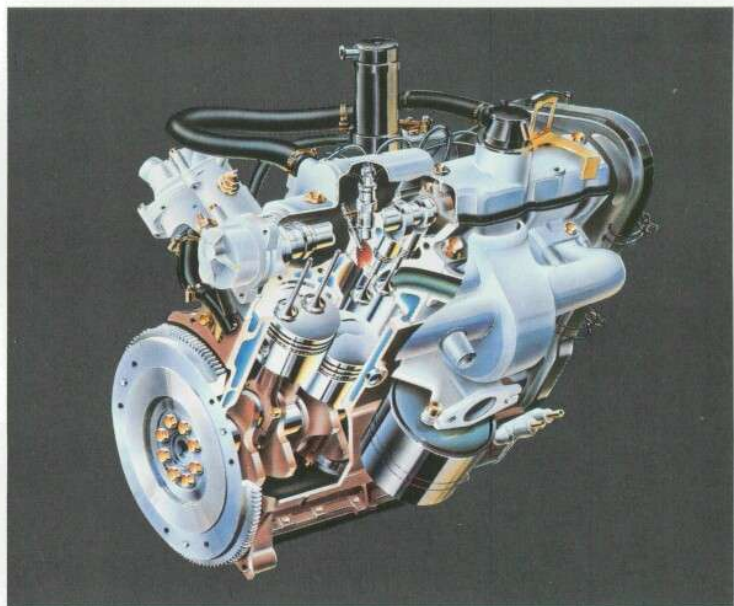

DES SOLUTIONS TECHNOLOGIQUES DE HAUT NIVEAU

AFIN DE CONFÉRER À CHAQUE 205 LES QUALITÉS EXEMPLAIRES DE CONFORT ET DE TENUE DE ROUTE QUI ONT FAIT LA RÉPUTATION DE LA MARQUE, PEUGEOT A SÉLECTIONNÉ DES SOLUTIONS TECHNIQUES DE HAUT NIVEAU POUR LES BOÎTES DE VITESSES ET LA SUSPENSION. EN OUTRE, POUR QUE LA TRANQUILLITÉ DU CONDUCTEUR ET DES PASSAGERS SOIT OPTIMALE EN TOUTES CIRCONSTANCES, UNE ATTENTION PARTICULIÈRE A ÉTÉ APPORTÉE À LA CONCEPTION DES ORGANES ET ÉQUIPEMENTS DE SÉCURITÉ.

HIGH LEVEL TECHNOLOGICAL SOLUTIONS

SO AS TO CONFER EXEMPLARY QUALITIES OF COMFORT AND ROAD-HOLDING ON EACH 205 WHICH HAVE MADE THE REPUTATION OF THE MAKE, PEUGEOT HAS SELECTED HIGH LEVEL TECHNICAL SOLUTIONS FOR THE GEARBOXES AND SUSPENSION. MOREOVER, IN ORDER THAT THE DRIVER AND PASSENGER SHOULD HAVE OPTIMUM TRANQUILITY IN ALL CIRCUMSTANCES, SPECIAL ATTENTION HAS BEEN PAID TO THE DESIGN OF THE SAFETY MECHANISMS AND EQUIPMENT.

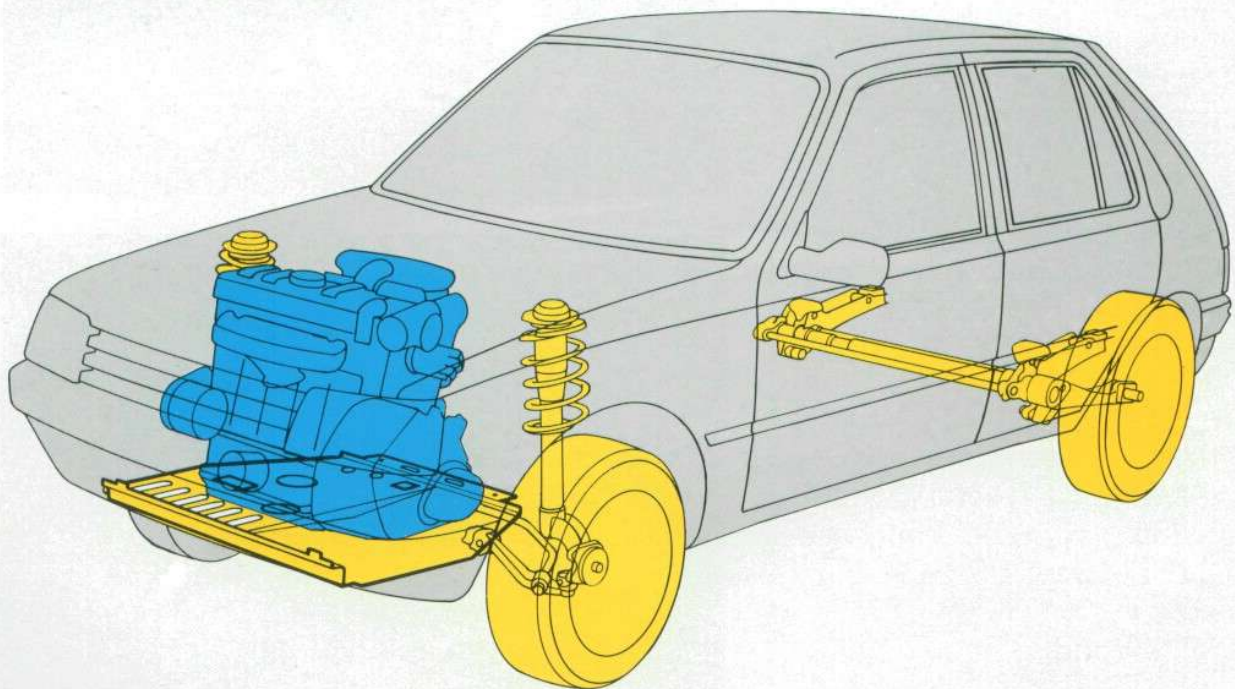

L'EXCELLENT ÉTAGEMENT DES BOÎTES DE VITESSES (4 RAPPORTS AVANT SUR 205 JUNIOR ET GLD, CINQ SUR TOUTES LES AUTRES), PERMET DE PRIVILÉGIER À LA FOIS LES PERFORMANCES ET LA SOBRIÉTÉ. TOUS LES MODÈLES BÉNÉFICIENT PAR AILLEURS D'UNE SUSPENSION RENFORCÉE ET D'UNE SOLIDE PLAQUE DE PROTECTION SOUS MOTEUR ET BOÎTE (SAUF LES GTI). LE FREINAGE EST ASSISTÉ PAR SERVO À DÉPRESSION ET LES FREINS AVANT SONT À DISQUES (VENTILÉS SUR 205 GTI) AVEC ÉTRIER FLOTTANT SUR TOUS MODÈLES.

THE EXCELLENT STAGING OF THE GEARBOX (FOUR FORWARD GEARS ON 205 JUNIOR AND GLD, FIVE ON ALL THE OTHERS), FAVORS BOTH PERFORMANCE AND ECONOMY. MOREOVER, ALL THE MODELS POSSESS STRENGTHENED SUSPENSION AND SOLID ENGINE AND GEARBOX PROTECTIVE PLATES (EXCEPT THE GTIs). BRAKING IS POWERED BY VACUUM SERVO AND THE FRONT BRAKES ARE DISC TYPE (VENTILATED ON THE 205 GTI) WITH FLOATING CALIPER ON ALL MODELS.

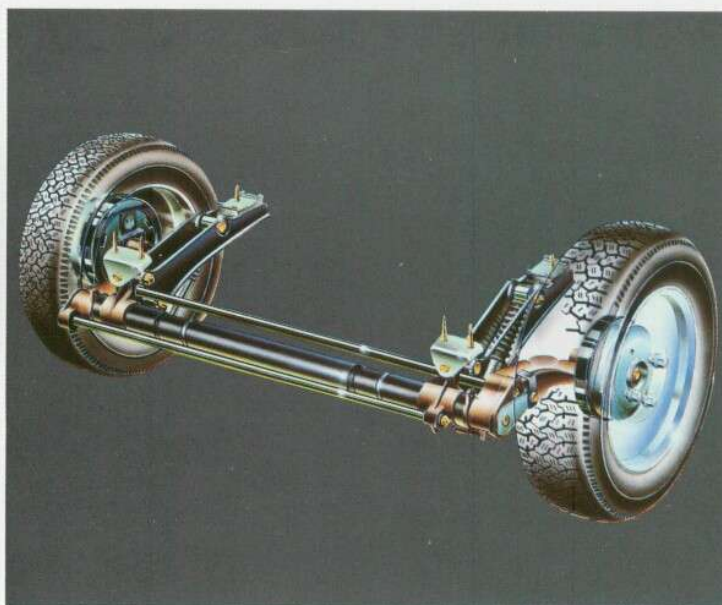
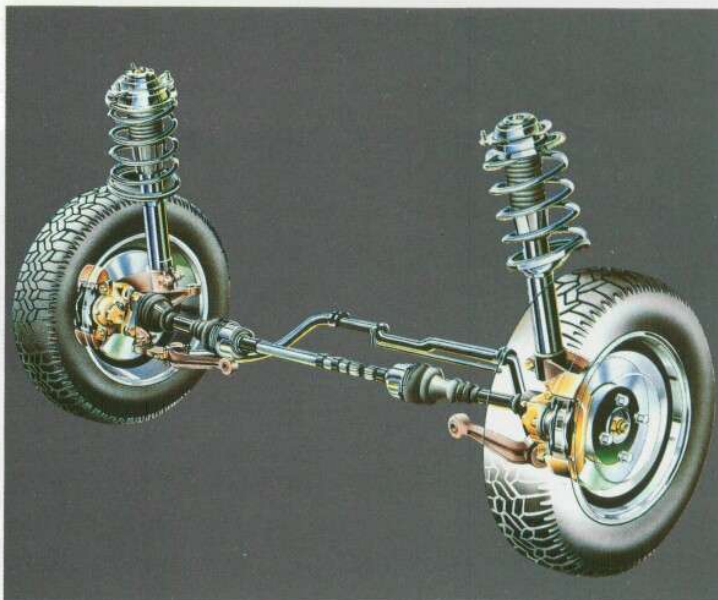

EQUIPEMENTS ET OPTIONS / EQUIPMENT AND OPTIONS



1. OPTION SIEGES GARNIS DE CUIR (GTI).
2. TOIT OUVRANT (OPTION SUR GTI).
3. ESSUIE-LAVE-VITRE.
4. VITRE LATÉRALE ARRIÈRE ENTROUVRABLE (SUR GTI).
5. RÉTROVISEUR EXTÉRIEUR À COMMANDE INTÉRIÈURE.
6. ROUE ALLIAGE LÉGER (GTI 1,9).

1. LEATHER SEAT TRIM OPTION (GTI).
2. SUN ROOF (OPTION ON GTI).
3. REAR SCREEN WIPE/WASH.
4. HINGED-OPENING REAR QUARTER WINDOWS (ON GTI).
5. INTERNALLY ADJUSTABLE DOOR MIRROR.
6. LIGHT ALLOY WHEELS (GTI 1.9).

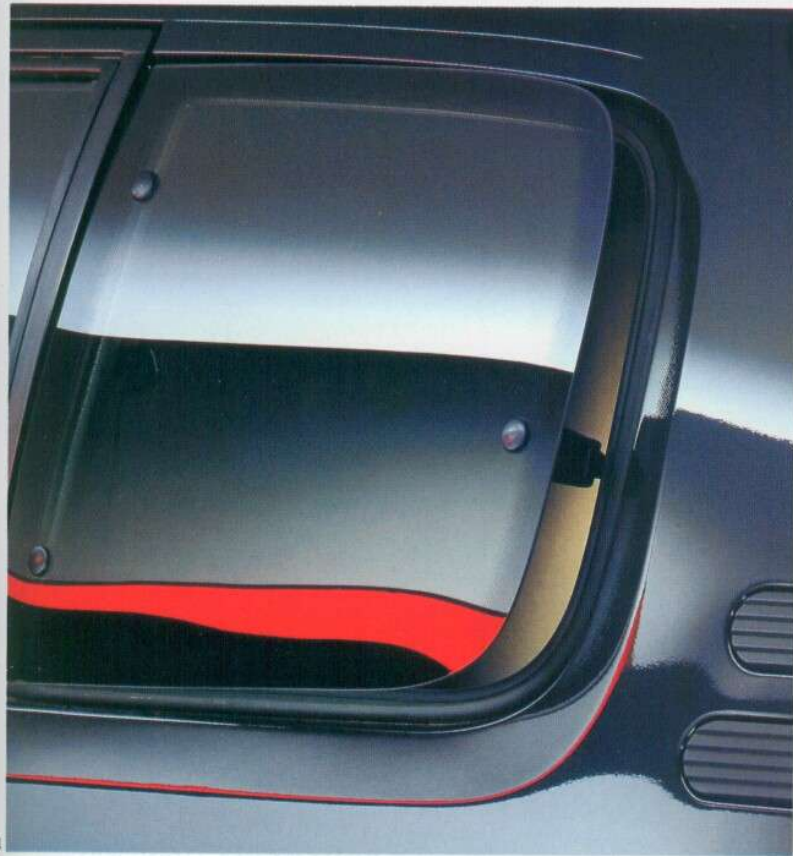
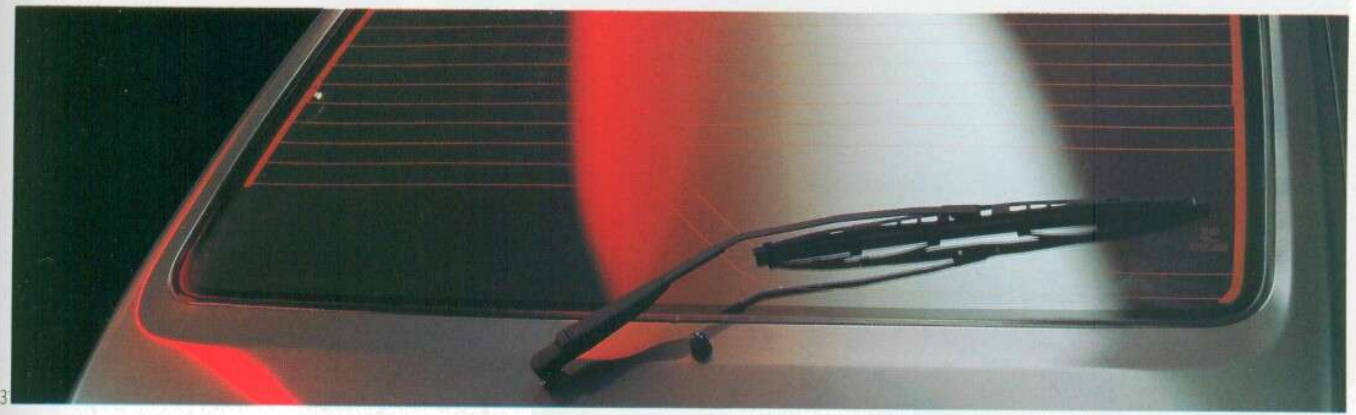
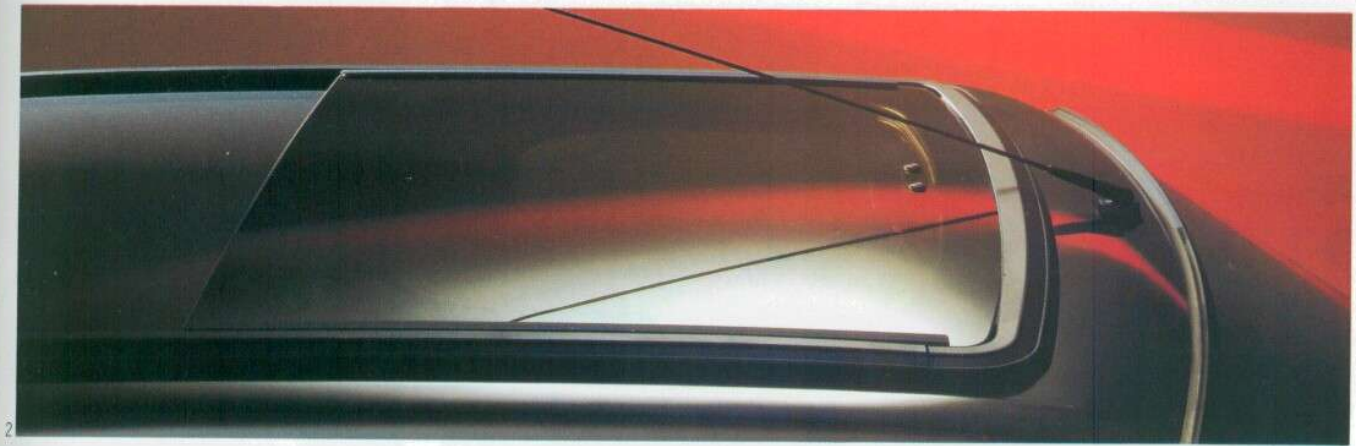

EQUIPEMENTS ET OPTIONS / EQUIPMENT AND OPTIONS



1



2

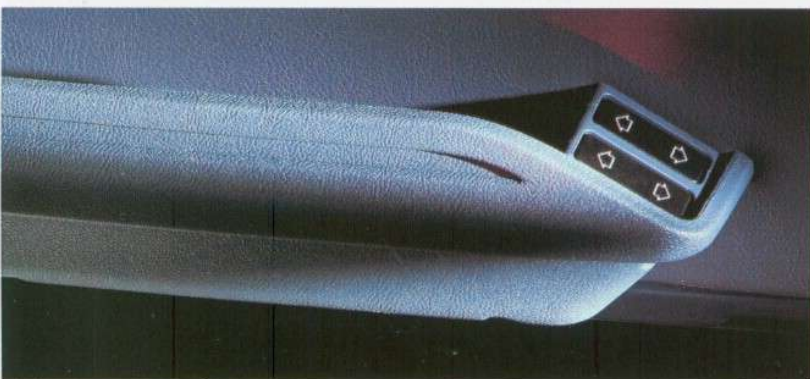

3

1. BANQUETTE ARRIÈRE RABATTUE.
2. BANQUETTE ARRIÈRE RABBATTABLE PAR MOITIÉ.
3. LÈVE-VITRES ÉLECTRIQUE.
4. LEVIER DE COMMANDE DE BOÎTE DE VITESSES À 5 RAPPORTS AVANT.
5. MONTRE A AIGUILLES.
6. BOÎTE À MONAIE.
7. MONTRE ÉLECTRONIQUE À AFFICHAGE NUMÉRIQUE.
8. COMMANDES DE CLIMATISATION.
9. POIGNÉE DE MAINTIEN.
10. PARE SOLEIL AVEC MIROIR DE COURTOISIE.
11. LECTEUR DE CARTES.
12. VERROUILLAGE CENTRALISÉ DES PORTES.
13. LEVIER DE BASCULEMENT DE SIÈGE AVANT (3 P).

1. REAR BENCH SEAT FOLDED DOWN.
2. 50/50 FOLDING REAR SEAT.
3. ELECTRIC FRONT WINDOWS.
4. MANUAL GEARBOX WITH 5 FORWARD SPEEDS.
5. QUARTZ ANALOGUE CLOCK.
6. COIN BOX.
7. ELECTRONIC DIGITAL CLOCK.
8. HEATING AND VENTILATION CONTROLS.
9. GRAB HANDLE.
10. SUN VISOR WITH VANITY MIRROR.
11. MAP READING LAMP.
12. CENTRAL LOCKING OF DOORS.
13. LEVER FOR FOLDING FRONT SEAT (3 D).

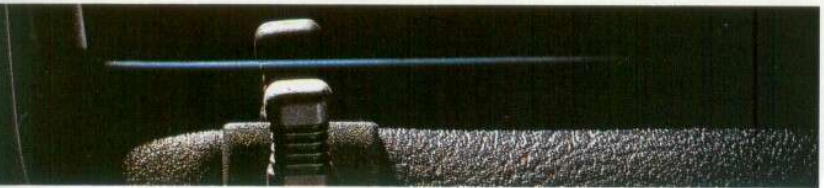
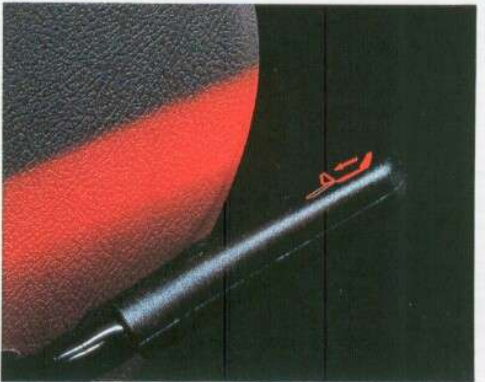
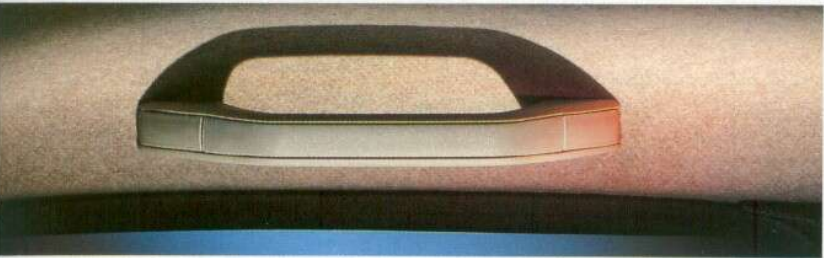
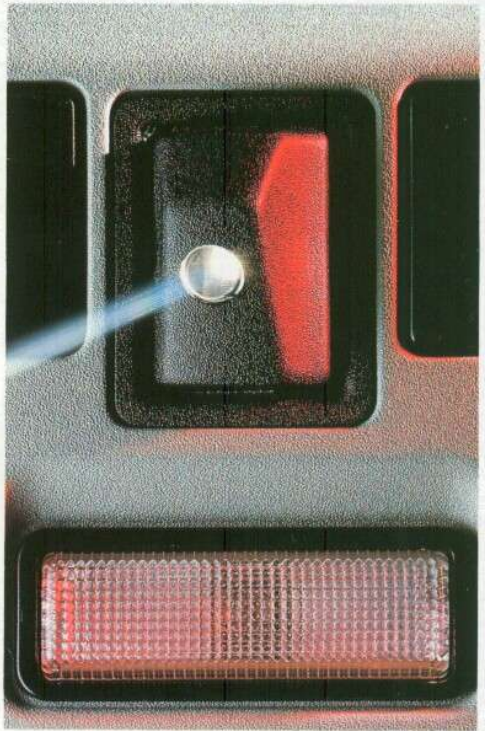
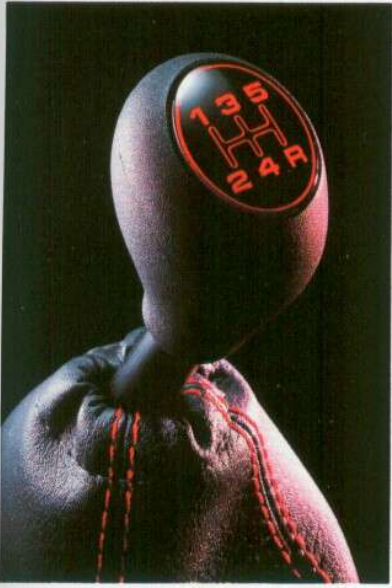

CARACTERISTIQUES TECHNIQUES 1992	205 JUNIOR	205 XL/GL	205 XR/GR/SR	205 GLD/GRD	205 XS	205 GTI 1,6	205 GTI 1,9
Moteur							
Cylindrée (en cm ³)	1124	1124	1360	1769	1360	1580	1905
Nombre de cylindres	4	4	4	4	4	4	4
Distribution par arbre à cames en tête	●	●	●	●	●	●	●
Alésage/course (en mm)	72 x 69	72 x 69	75 x 77	80 x 88	75 x 77	83 x 73	83 x 88
Puissance ● norme CEE (kW)	40 à 5800	40 à 5800	55 à 5800	43,5 à 4600	61,5 à 6400	83 à 6250	93,5 à 6000
maxi à tr/mn : ● norme DIN (ch)	55 à 5800	55 à 5800	75 à 5800	60 à 4600	85 à 6400	115 à 6250	130 à 6000
Couple maxi ● norme CEE (mdaN)	8,75 à 3200	8,75 à 3200	11,4 à 3800	10,6 à 2000	11,4 à 4000	13,1 à 4000	16,1 à 4750
à tr/mn : ● norme DIN (mkg)	9,1 à 3200	9,1 à 3200	11,8 à 3800	11 à 2000	11,8 à 4000	13,6 à 4000	16,8 à 4750
Alimentation : ● carburateur	●	●	●		1 double corps		
● injection E/D				● D		● E	● E
Taux de compression	9,4/1	9,4/1	9,3/1	23/1	9,3/1	9,8/1	9,6/1
Dispositif de départ à froid : ● manuel	●	●	●				
● automatique					●	●	●
Dispositif de préchauffage				●			
Allumage électronique	●	●	●		●	●	●
Bougies hautes performances	●	●	●		●	●	●
Transmission							
Boîte de vitesses manuelle : ● 4 rapports avant synchronisés	●			● GLD			
● 5 rapports avant synchronisés		●	●	● GRD	●	●	●
Embrayage monodisque à sec avec butée de débrayage à billes	●	●	●	●	●	●	●
Direction							
Assistée						○	○
Nombre de tours de volant de butée à butée : ● assistée						2,8	3
● non assistée	3,8	3,8	3,8	3,8	3,8	3,8	3,6
Rayon de braquage hors tout (en mètres)	5,25	5,25	5,25	5,25	5,25	5,4	5,85
Suspension							
Avant : A roues indépendantes, ressorts hélicoïdaux, barre antidévers et amortisseurs hydrauliques, télescopiques à double effet.							
Arrière : A roues indépendantes, barres de torsion, barre antidévers et amortisseurs hydrauliques, télescopiques à double effet.							
Freins à double circuit							
Avant : ● à disques à étriers flottants	●	●	●	●	●		
● à disques ventilés et étriers flottants						●	●
Arrière : ● à tambours à rattrapage automatique d'usure et compensateur à inertie	●	●	●	●	●	●	
● à disque à rattrapage automatique d'usure et compensateur à inertie							●
Servofrein	●	●	●	●	●	●	●
Équipement électrique							
Générateur électrique (alternateur triphasé) ● sans réfrigération				750 W/50 A			
● avec réfrigération				1000 W/70 A			
Batterie	12 V/29 Ah	12 V/29 Ah	12 V/29 Ah	12 V/42 Ah	12 V/29 Ah	12 V/29 Ah	12V/29 Ah
Dimensions (en mètres)							
Longueur hors tout	3,705	3,705	3,705	3,705	3,705	3,705	3,705
Largeur hors tout	1,572	1,572	1,572	1,560	1,562	1,589	1,589
Empattement	2,420	2,420	2,420	2,420	2,420	2,420	2,425
Voies ● avant	1,350	1,350	1,350	1,364	1,364	1,393	1,383
● arrière	1,304	1,304	1,304	1,318	1,318	1,328	1,344
Hauteur hors tout	1,374	1,374	1,374	1,368	1,374	1,355	1,355
Largeur ● avant	1,310	1,310	1,310	1,310	1,310	1,310	1,310
aux coudes ● arrière	1,305	1,305	1,305	1,305	1,305	1,305	1,305
Nombre de places	5	5	5	5	5	5	5
Poids (en kilogrammes)							
En ordre de marche	765	765	840	880	820	850	880
Total autorisé en charge	1195	1195	1255	1300	1230	1275	1300
Charge remorquable, remorque freinée	800	800	800	900	900	900	900
Total roulant autorisé	1895	1895	2055	2100	2030	2075	2100
Capacités (en litres)							
Réservoir de carburant	50	50	50	50	50	50	50
Carter d'huile moteur	3,5	3,5	3,5	5	3,5	5	5
Volume total du coffre ● avec tablette et banquette ou sièges arrière	216	216	216	216	216	216	216
● sans tablette et banquette ou sièges arrière rabattus	564 à 1200	564 à 1200	564 à 1200	564 à 1200	564 à 1200	564 à 1200	564 à 1200
Performances							
Vitesse maximale en km/h (sur circuit)	154	157	172	156	178	196	206
Accélérations ● de 0 à 100 km/h (en sec.) : ● 1000 m départ arrêté	14,6	14,6	11,8	15,1	10,6	9,1	7,8
	36,4	36,2	33,7	36,5	32,5	30,4	29,2
Pneumatiques				145 R 13 S AVEC CHAMBRE A AIR		185/60R14H	185/55R15V
Consommations (en litres aux 100 km)	Super	Super	Super	Gazole	Super	Super	Super
mesurées ● à 90 km/h en vitesse stabilisée	4,5	4,5	4,8	3,9	5,2	5,9	5,9
par ● à 120 km/h en vitesse stabilisée	5,9	5,9	6,7	5,2	7,0	7,5	7,7
l'U.T.A.C. : ● en parcours urbain	6,5	6,7	7,7	5,4	8,6	9,2	9,7

● Équipements de base / ○ option.

La suspension est adaptée aux conditions locales de circulation.

En fonction de la qualité des carburants disponibles, le constructeur peut être amené à modifier certaines caractéristiques des moteurs, entraînant ainsi une variation des spécifications.

ENGINE CHARACTERISTICS	205 JUNIOR	205 XL/GL	205 XR/GR/SR	205 GLD/GRD	205 XS	205 GTI 1,6	205 GTI 1,9	
Engine								
Displacement (in cm ³)	1124	1124	1360	1769	1360	1580	1905	
Number of cylinders	4	4	4	4	4	4	4	
Overhead cam shaft	●	●	●	●	●	●	●	
Bore/stroke (in mm)	72 x 69	72 x 69	75 x 77	80 x 88	75 x 77	83 x 73	83 x 88	
Max. power	● EEC standard (kW)	40 at 5800	40 at 5800	55 at 5800	43,5 at 4600	61,5 at 6400	83 at 6250	93,5 at 6000
at rpm.:	● DIN standard (bhp)	55 at 5800	55 at 5800	75 at 5800	60 at 4600	85 at 6400	115 at 6250	130 at 6000
Max. torque	● EEC standard (daNm)	8,75 at 3200	8,75 at 3200	11,4 at 3800	10,6 at 2000	11,4 at 4000	13,1 at 4000	16,1 at 4750
at rpm.:	● DIN standard (kg.m)	9,1 at 3200	9,1 at 3200	11,8 at 3800	11 at 2000	11,8 at 4000	13,6 at 4000	16,8 at 4750
Carburation:	● carburettor	●	●		1 double barrel			
	● P/D injection			● D		● P	● P	
Compression ratio	9,4/1	9,4/1	9,3/1	23/1	9,3/1	9,8/1	9,6/1	
Cold start device:	● Manual	●	●					
	● Automatic				●	●	●	
Pre-heating device				●				
Electronic ignition	●	●	●		●	●	●	
High performances spark plugs	●	●	●		●	●	●	
Transmission								
Manual gearbox:								
	● 4 synchronized forward speeds	●		● GLD				
	● 5 synchronized forward speeds		●	● GRD	●	●	●	
Single dry disc clutch with ball-bearing thrust mechanism	●	●	●	●	●	●	●	
Steering								
Power steering						○	○	
Numbers of turns lock to lock:								
	● Power steering					2,8	3	
	● Manuel steering	3,8	3,8	3,8	3,8	3,8	3,6	
Turning radius between curbs (in meters)	5,25	5,25	5,25	5,25	5,25	5,4	5,85	
Suspension								
Front:	Independant, coil springs, anti-sway bar and dual action telescopic, hydraulic shock absorbers.							
Rear:	Independant, torsion bars, anti-sway bar and dual effect telescopic, hydraulic shock absorbers							
Brakes								
double-circuit								
Front:	● Floating caliper disc	●	●	●	●			
	● Ventilated disc and floating caliper					●	●	
Rear:	● Drum with automatic wear correction and inertia equalizer	●	●	●	●	●		
	● Disc with automatic wear correction and inertia equalizer						●	
Servo-brake	●	●	●	●	●	●	●	
Electrical equipment								
Electrical generator (3 phase alternator)								
	● Without air conditioning			750 W/50 A				
	● With cooling circuit			1000 W/70 A				
Battery	12 V/29 Ah	12 V/29 Ah	12 V/29 Ah	12 V/42 Ah	12 V/29 Ah	12 V/29 Ah	12V/29 Ah	
Dimensions (in meters)								
Overall length	3,705	3,705	3,705	3,705	3,705	3,705	3,705	
Overall width	1,572	1,572	1,572	1,560	1,562	1,589	1,589	
Wheelbase	2,420	2,420	2,420	2,420	2,420	2,420	2,425	
Tracks	● Front	1,350	1,350	1,350	1,364	1,364	1,393	
	● Rear	1,304	1,304	1,304	1,318	1,318	1,328	
Overall height	1,374	1,374	1,374	1,368	1,374	1,355	1,355	
Elbow room:	● Front	1,310	1,310	1,310	1,310	1,310	1,310	
	● Rear	1,305	1,305	1,305	1,305	1,305	1,305	
Seating capacity 5	5	5	5	5	5	5	5	
Weight (in kilograms)								
Kerb weight	765	765	840	880	820	850	880	
Maximum laden	1195	1195	1255	1300	1230	1275	1300	
Towing capacity, trailer with brakes	800	800	800	900	900	900	900	
Maximum train weight	1895	1895	2055	2100	2030	2075	2100	
Capacities (in litres)								
Fuel tank	50	50	50	50	50	50	50	
Crankcase (oil)	3,5	3,5	3,5	5	3,5	5	5	
Total trunk volume	● With shelf and rear bench or seats up	216	216	216	216	216	216	
	● Without shelf and rear bench or seats folded down	564 at 1200	564 at 1200	564 at 1200	564 at 1200	564 at 1200	564 at 1200	
Performances								
Maximum speed in km/h (closed track)	154	157	172	156	178	196	206	
Acceleration	● From 0 to 100 km/h	14,6	14,6	11,8	15,1	10,6	9,1	
(in seconds):	● 1,000 m from standing start	36,4	36,2	33,7	36,5	32,5	30,4	
Tyres	145 R 13 S WITH INNER TUBE					185/60R14H		185/55R15V
Consumption (litres per 100 km)								
as measured	● At constant 90 Km/h	4,5	4,5	4,8	3,9	5,2	5,9	
by UTAC	● At constant 120 km/h	5,9	5,9	6,7	5,2	7,0	7,7	
	● Urban driving	6,5	6,7	7,7	5,4	8,6	9,7	

● Basic equipment. /○ Options.

Suspension is adapted for local driving conditions.

Depending on the quality of local available fuels the manufacturer may be forced to modify certain engine characteristics with an effect on the specified performance and consumption.

Équipements du tableau de bord	205dTi	205dTi,0	205dTi,9	205dTi,9	205dTi,9	205dTi,9
Témoin de température d'eau	●	●	●	●	●	●
Témoin de niveau mini d'eau	●	●	●	●	●	●
Indicateur de niveau de carburant	●	●	●	●	●	●
Témoin de niveau mini de carburant	●	●	●	●	●	●
Témoin d'usure des plaquettes de freins avant*	●	●	●	●	●	●
Témoin de niveau mini de liquide de freins*	●	●	●	●	●	●
Témoin de frein à main*	●	●	●	●	●	●
Témoin de pression mini d'huile moteur	●	●	●	●	●	●
Témoin de charge de la batterie	●	●	●	●	●	●
Témoin de starter	●	●	●	●	●	●
Témoin de présence d'eau dans le gazole	●	● (XL/GL)	● (XR/GR)	●	●	●
Témoin de préchauffage	●	● (GLD)	● (GRD)	●	●	●
Témoin d'alerte centralisée (eau, huile)	●	● (GLD)	● (GRD)	●	●	●
Témoin des feux : lanternes, croisement, route	●	●	●	●	●	●
Alarme oubli extinction feux	●	●	●	●	●	●
Compte-tours électronique	●	●	●	●	●	●
Montre électrique à quartz	●	●	●	●	●	●
Montre électronique à affichage numérique	●	●	●	●	●	●
Compteur kilométrique journalier	●	●	●	●	●	●
Rhéostat d'éclairage du combiné	●	●	●	●	●	●
Équipements de conduite et de sécurité						
Pare-brise feuilleté	●	●	●	●	●	●
Toutes vitres teintées	○/○○	○/○○	●	●	●	●
Vitres latérales arrière entrouvrables	●	●	●	●	●	●
Essuie-vitre 2 vitesses et lave-vitre à commande électrique	●	●	●	●	●	●
Essuie-vitre intermittent	●	●	●	●	●	●
Projecteurs principaux à iode (H4)	●	●	●	●	●	●
Projecteurs longue portée à iode (H1)	●	●	●	●	●	●
Projecteurs principaux réglables à 2 positions d'assiette	●	●	●	●	●	●
Feu de recul	●	●	●	●	●	●
Feu arrière de brouillard	●	●	●	●	●	●
Dégivrage/desembuage de la lunette arrière	●	●	●	●	●	●
Lave/essuie-vitre de lunette arrière	○	○	●	●	●	●
Rétroviseurs extérieurs réglables de l'intérieur	●	●	●	●	●	●
Baguettes de protection latérale	●	●	●	●	●	●
Becquet arrière	●	●	●	●	●	●
Dégivrage/desembuage des vitres latérales avant	●	●	●	●	●	●
Rétroviseur intérieur jour et nuit	●	●	●	●	●	●
Ceintures de sécurité avant à enrouleur	●	●	●	●	●	●
Sécurité enfants sur portes arrière	●	●	●	●	●	●
Plaque de protection sous moteur	●	●	●	●	●	●
Équipements de confort et de finition						
Peinture noire vernie	●	○	○	○	○	○
Peinture métallisée vernie	○	○	○	○	○	○
Toit ouvrant	○	○	○	○	○	○
Verrouillage électrique centralisé des portes et du coffre	●	●	○○○	●	○○	○○
Commande verrouillage à distance	●	●	●	●	○○	○○
Bouchon carburant fermant à clé	●	●	●	●	●	●
Lève-vitres avant à commande électrique	●	●	○○○	●	○○	○○
Équipement pour autoradio comprenant :						
● Câble coaxial, antiparasitage, alimentation de récepteur, emplacements récepteur et haut-parleurs avant	●	●	●	●	●	●
● Antenne, câble coaxial, antiparasitage, faisceau de raccordement et emplacements récepteur et haut-parleurs avant	●	●	●	●	●	●
Climatisation air chaud et froid avec soufflerie à rhéostat	●	●	●	●	●	●
Réfrigération de l'habitacle	○○	○○	○	○	○	○
Sieges avant séparés à dossier inclinable	●	●	●	●	●	●
● basculants pour dégager l'accès vers l'arrière	●	●	●	●	●	●
● type "baquet"	●	●	●	●	●	●
Appuis-tête sur sièges avant	●	●	●	●	●	●
Garnissage des sièges	●	●	○	○	○	○
● drap	●	●	●	●	●	●
● vinyle	●	○	○	○	○	○
● velours	●	○	○	○	○	○
● velours/cuir - ○ tout cuir	●	○	○	○	○	○
Plancher recouvert de moquette	●	●	●	●	○	○/○
Console centrale	●	●	●	●	●	●
Allume-cigares	●	●	●	●	●	●
Cendriers	●	●	●	●	●	●
● avant	●	●	●	●	●	●
● arrière	●	●	●	●	●	●
Accoudoirs de portes :	●	●	●	●	●	●
● avant	●	●	●	●	●	●
● arrière	●	●	●	●	●	●
Poignées de maintien :	●	●	●	●	●	●
● avant (1)	●	●	●	●	●	●
● arrière (2)	●	●	●	●	●	●
Tablette sous planche de bord :	●	●	●	●	●	●
● côté conducteur	●	●	●	●	●	●
● côté passager	●	●	●	●	●	●
Vide-poches dans les portes avant :	●	●	●	●	●	●
● côté conducteur	●	●	●	●	●	●
● côté passager	●	●	●	●	●	●
Boîte à gants	●	●	●	●	●	●
● avec couvercle	●	●	●	●	●	●
● avec serrure et éclairage	●	●	●	●	●	●
Pare-soleil avant conducteur/passager	●	●	●	●	●	●
Miroir de courtoisie sur les pare-soleil avant	●	●	●	●	●	●
Plafonnier à l'avant	●	●	●	●	●	●
Lecteur de cartes à l'avant	●	●	●	●	●	●
Éclairage dans le coffre	●	●	●	●	●	●
4 jantes en alliage léger	○	○	○	○	○	○
Tapis de coffre	●	●	●	●	●	●
Banquette arrière rabattable	●	●	●	●	●	●
Banquette arrière rabattable en 2 parties	○	○	○	○	○	○

● Équipements de base / ○ options / ○○○/○○○ Options groupées. * Témoins groupés.
 *En fonction des dispositions législatives et réglementaires nationales, les caractéristiques techniques et l'équipement des modèles figurant dans la présente brochure sont susceptibles de varier d'un pays à l'autre : votre concessionnaire vous apportera toutes précisions utiles."

1992 EQUIPMENT AND OPTIONS	205 JUNIOR	205 XL/GL/GLD	205 XR/GR/GRD	205 SR	205 XS	205 GTI 1,6	205 GTI 1,9
Dashboard accessories							
Water temperature light	●	●	●	●	●	●	●
Minimum water level light	●	●	●	●	●	●	●
Fuel gauge indicator	●	●	●	●	●	●	●
Low fuel warning light	●	●	●	●	●	●	●
Front brake pad wear warning light*	●	●	●	●	●	●	●
Brake fluid warning light*	●	●	●	●	●	●	●
Hand brake indicator light*	●	●	●	●	●	●	●
Engine oil pressure warning light	●	●	●	●	●	●	●
Battery charging warning light	●	●	●	●	●	●	●
Choke indicator light	●	● (XL/GL)	● (XR/GR)	●	●	●	●
Water in diesel fuel warning light	●	● (GLD)	● (GRD)	●	●	●	●
Preheater indicator light	●	● (GLD)	● (GRD)	●	●	●	●
Centralized warning light (water, oil)	●	●	●	●	●	●	●
Light indicator: sidelights, dipped headlights, full beam	●	●	●	●	●	●	●
Lights on warning buzzer	●	●	●	●	●	●	●
Electronic tachometer	●	●	●	●	●	●	●
Electric quartz clock	●	●	●	●	●	●	●
Electronic digital display clock	●	●	●	●	●	●	●
Daily trip mileage counter	●	●	●	●	●	●	●
Instrument panel lighting control	●	●	●	●	●	●	●
Driving and safety accessories							
Laminated windshield	●	●	●	●	●	●	●
All-around tinted windows	○/○○	○/○○	●	●	●	●	●
Opening rear quarter windows	●	●	●	●	●	●	●
2-speed windshield wiper with electric washer	●	●	●	●	●	●	●
Intermittent action windshield wiper	●	●	●	●	●	●	●
Halogen main headlights (H4)	●	●	●	●	●	●	●
Halogen long range driving lamps (H1)	●	●	●	●	●	●	●
Adjustable main headlights with 2 trim settings	●	●	●	●	●	●	●
Reversing light	●	●	●	●	●	●	●
Rear fog light	●	●	●	●	●	●	●
Rear window defogger/de-icer	●	●	●	●	●	●	●
Rear window washer/wiper	○	○	●	●	●	●	●
Outside rear view mirrors adjustable from inside	●	●	●	●	●	●	●
Body side rubbing strips	●	●	●	●	●	●	●
Rear spoiler	●	●	●	●	●	●	●
Front side windows defogger/de-icer	●	●	●	●	●	●	●
Day/night inside rear view mirror	●	●	●	●	●	●	●
Front inertia-reel seatbelts	●	●	●	●	●	●	●
Childproof rear door locks	●	●	●	●	●	●	●
Protection leaf under engine	●	●	●	●	●	●	●
Comfort and finishing accessories							
Varnished black paint	●	○	○	○	○	○	○
Varnished metallic paint	○	○	○	○	○	○	○
Sun roof	○	○	○	○	○	○	○
Central locking of doors and tailgate	●	●	○○○	●	○○	○○	●
Remote control locking	●	●	●	●	●	○○	●
Locking fuel cap	●	●	●	●	●	●	●
Electric front windows	●	●	○○○	●	○○	○○	●
Fittings for car radio including : ● Coaxial cable, interference suppressor, power supply for receiver, housings for receiver and front speakers	●	●	●	●	●	●	●
● Aerial, coaxial cable, interference suppressor, wiring loom and housings for receiver and front speakers	●	●	●	●	●	●	●
Hot and cold air flow with blower speed control	●	●	●	●	●	●	●
Air conditioning	○○	○○	○	○	○	○	○
Separate front seats with reclining backs	●	●	●	●	●	●	●
● tip-forward type for access to rear	●	●	●	●	●	●	●
● bucket type	●	●	●	●	●	●	●
Front seat head rests	●	●	●	●	●	●	●
Upholstery :	●	●	●	●	●	●	●
● cloth	●	●	●	●	●	●	●
● vinyl	○	○	○	○	○	○	○
● velours	●	●	●	●	●	●	●
● velours/leather ○ all-leather	○	○	○	○	○	○	○
Carpeted floor	●	●	●	●	●	●	●
Centre console	●	●	●	●	●	●	●
Cigar lighter	●	●	●	●	●	●	●
Ashtrays	●	●	●	●	●	●	●
● front	●	●	●	●	●	●	●
● rear	●	●	●	●	●	●	●
Door arm rests :	●	●	●	●	●	●	●
● front	●	●	●	●	●	●	●
● rear	●	●	●	●	●	●	●
Grab handles :	●	●	●	●	●	●	●
● front (1)	●	●	●	●	●	●	●
● rear (2)	●	●	●	●	●	●	●
Tray beneath dashboard :	●	●	●	●	●	●	●
● driver's side	●	●	●	●	●	●	●
● passenger's side	●	●	●	●	●	●	●
Storage pockets in front doors :	●	●	●	●	●	●	●
● driver's side	●	●	●	●	●	●	●
● passenger's side	●	●	●	●	●	●	●
Glove compartment	●	●	●	●	●	●	●
● with lid	●	●	●	●	●	●	●
● with lock and light	●	●	●	●	●	●	●
Front sun visor driver/passenger	●	●	●	●	●	●	●
Courtesy mirror on passenger sun visor	●	●	●	●	●	●	●
Front dome light	●	●	●	●	●	●	●
Front map light	●	●	●	●	●	●	●
Trunk light	●	●	●	●	●	●	●
4 light alloy wheel rims	○	○	○	○	○	○	○
Carpeted trunk	●	●	●	●	●	●	●
One-piece folding rear seat	●	●	●	●	●	●	●
2-piece folding rear seat	○	○	○	○	○	○	○

● Basic equipment./○ options./○○/○○○ Combined Options. * Combined indicators.

Technical characteristics and equipment for the models shown in this brochure may vary as required by regulations in different countries. Ask your dealer for details.

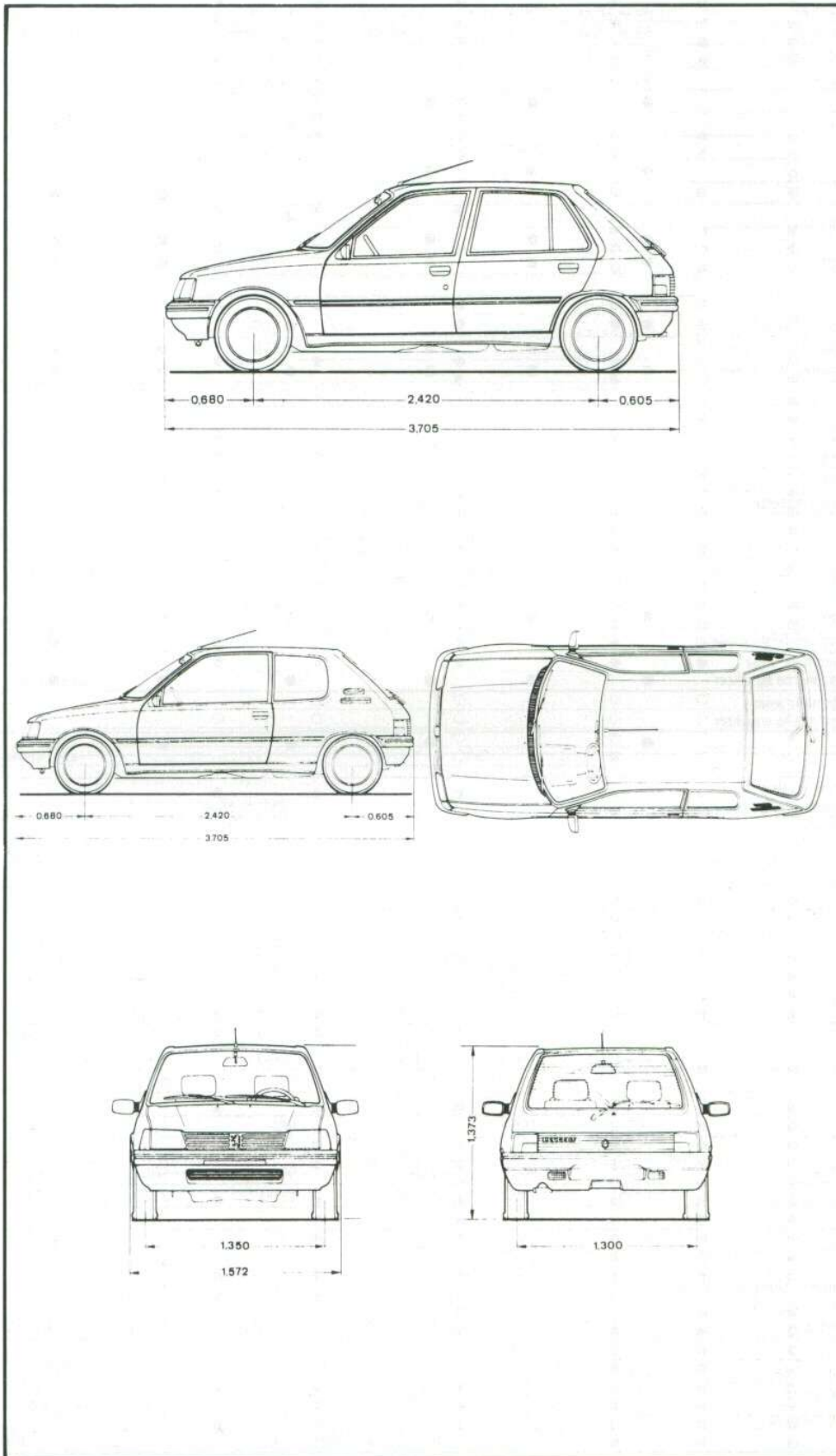

DAO F/GB 1C122

 PEUGEOT

CREATION RESSOURCES/HDM - PRODUCTION CATHEDRA - AUTOMOBILES PEUGEOT RC PARIS B 552 144 503 - EDITION L.A. PUBLICITE FRANCAISE - IMP. EN C.E.E